

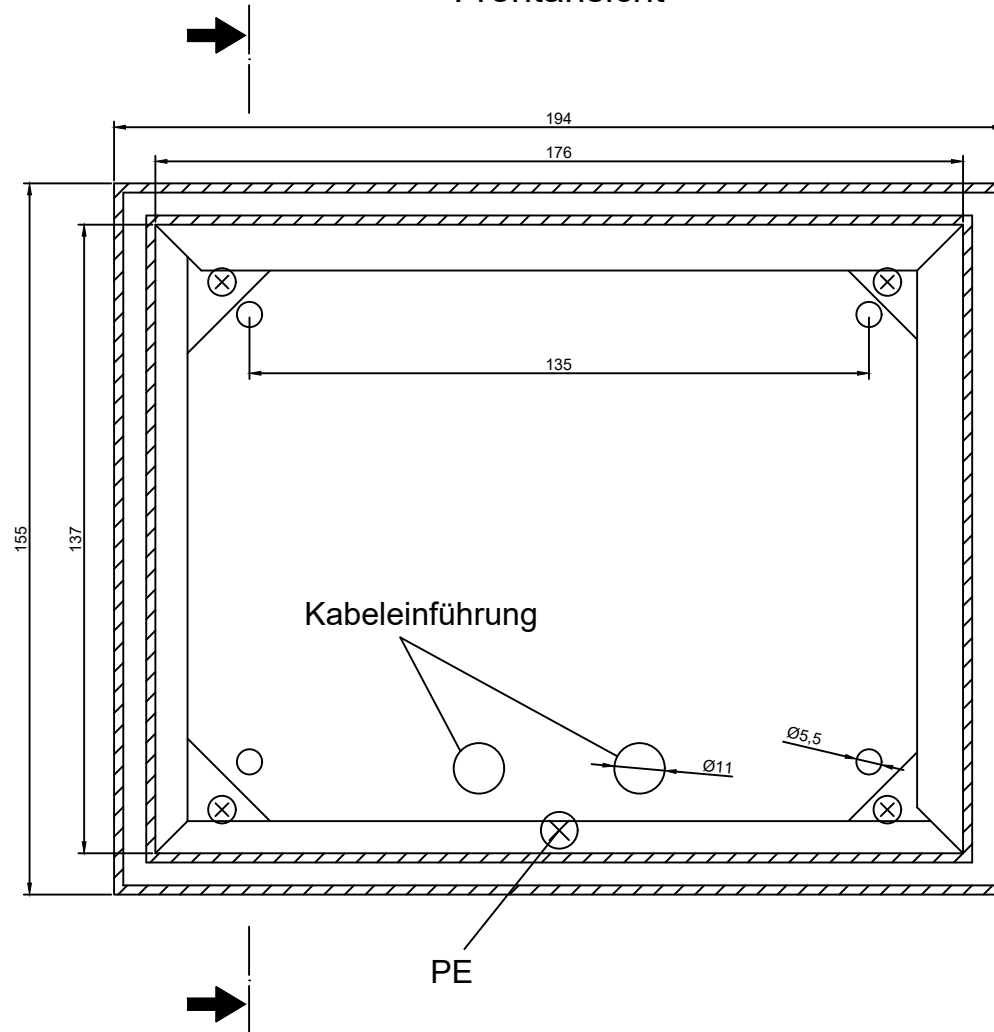

### Frontansicht

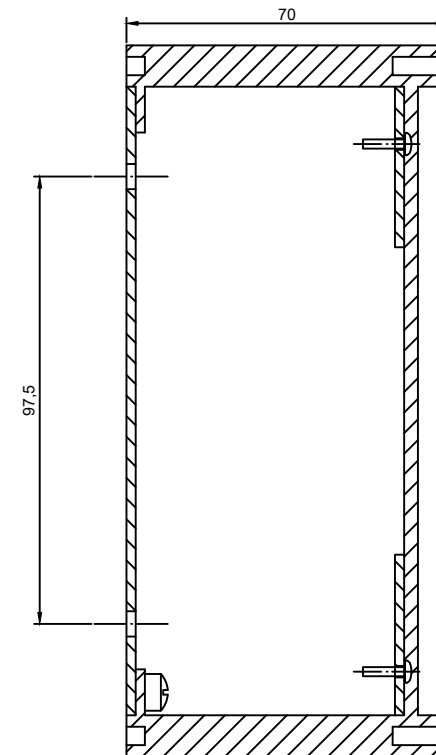

### Schnitt



AP-Gehäuse Aluminium silberhell eloxiert E6/EV1  
 Größe 194x155x70mm  
 inkl. Aufnahmehalterung für Siemens Panel UB588 V12

|        |            |  |   |
|--------|------------|--|---|
| Datum  | 01.09.2019 | ESB-Energie Signal Bau<br>Königstr.6a D-23847 Rethwisch<br>Tel.: 04539/1802-50 Fax -70 | <br><a href="http://www.esbonline.de">www.esbonline.de</a> |
| Bearb. | Hartmann   |  |   |
| Gepr.  |            | Benennung:   | Siemens UP588 V12<br>Aufputzgehäuse   |
| Norm   |            |  |   |
| Blatt  | 1/1        |  |   |